



*Mineral Sanitizers
for Pools*



Nature2® Professional G Inground Sanitizer Vessel Installation and Operating Manual

Important Safety Information

Please read this manual prior to installation.

Thank you for purchasing Nature². This Nature² Professional G Inground Vessel provides the housing for the G Inground Replacement Cartridge which is sold separately. Always refer to the owner's manual included with your cartridge for proper start-up procedures and the required low chlorine recipe. If you have questions, your Nature² dealer can provide professional advice and service.



WARNING

Failure to heed the following warnings can result in permanent injury or drowning.

EQUIPMENT UNDER PRESSURE

- In order to minimize risk of property damage and/or serious injury, including loss of life, always turn pump off prior to installing or changing Nature² cartridge. Your pump/filter system is operated under pressure and the pressure must be released before you begin work. Please see your pump/filter owner's manual for further instructions.

PREVENT CHILD DROWNING

- Do not let anyone, especially small children, sit, step, lean or climb on any equipment installed as part of your pool's operational system. Locate the components of your operational system at least 3 feet from the pool so children cannot use the equipment to access the pool and be injured or drown.

Specifications

Capacity: Up to 45,000 gallons

Dimensions: 20" x 11" x 11.5"

Ports: 2" PVC SKT inlet and outlet or 1.5" FPT

Weight: 10 lbs

Circulation system flow rate: 30-120 GPM

Vessel flow rate: 10-18 GPM (internal by-pass)

Maximum operating pressure: 50 PSI

Replacement cartridge: (sold separately)

G25 10,000 to 25,000 gallons

G35 25,000 to 35,000 gallons

G45 35,000 to 45,000 gallons

Important: The proper replacement cartridge model is indicated on the front label of your Nature² vessel.

Limited warranty: Vessel - 5 years

The Nature² Pool Sanitizer is designed for residential swimming pools only.

IMPORTANT:

Pool owner, save this manual.

Builder, leave this manual with pool owner.

Installation

This vessel has been equipped with an automatic flow-control device, designed to properly regulate the correct amount of water through the cartridge. Under normal pump and filter pressure conditions on inground pool systems, the flow rate to the inlet side of the vessel is 30 to 80 gpm.

If your pump system is designed to produce flow rates greater than 80 gpm, you should remove the orange flow control diaphragm from the vessel prior to installation. If your pump system is designed to produce flow rates greater than 120 gpm or if plumbing is greater than 2", install the vessel in a bypass configuration.

Install the Vessel

Refer to the diagram below for part references.

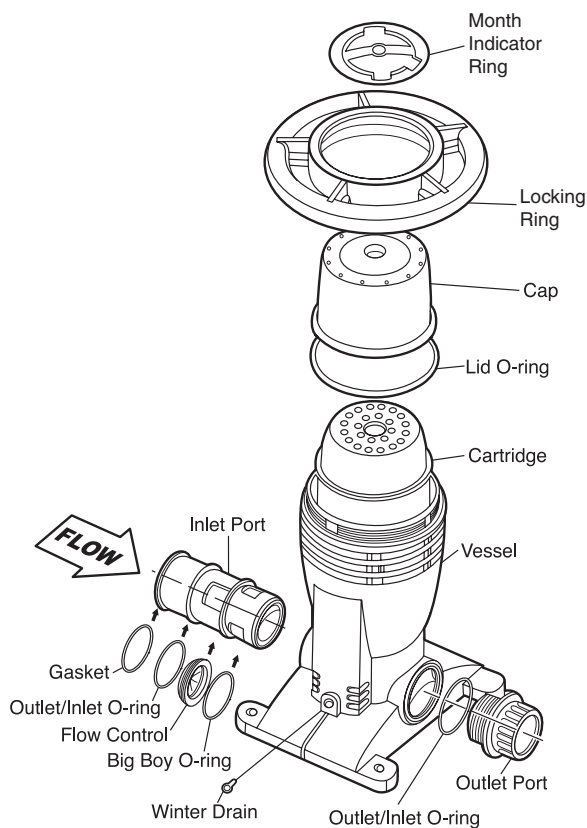

1. Decide where to install the Nature²® vessel. It must be installed:
 - On a concrete slab to support the weight of the vessel.
 - After the filter on the main return to the pool.
 - Before or after the heater (downstream of solar heating systems).
 - Before any chemical dispenser or the discharge of any off-line chemical dispenser. **IMPORTANT: Install a check valve before chlorinators to isolate the Nature²® vessel from possible backflow of highly chlorinated water.**

2. Locate the 2" socket inlet port and outlet port connections on the vessel.
3. **Make sure the pump and filter are turned off.** Connect the outlet from the filter to the vessel inlet port with the appropriate Schedule 40 PVC pipe*; secure the connection with a pipe glue that is compatible with PVC.
4. Connect the vessel outlet port to the pool return line with the same type of PVC pipe*; secure the connection with the pipe glue.
5. Allow sufficient time for the glue to dry.
6. Screw on the locking ring until it is snug. Do not overtighten. Check that all connections are secure.

Important: Do not install the Nature² Cartridge until the vessel installation is complete.

7. Start the pump and check for leaks.

Bypass Installation

Install the 2" Nature² vessel in bypass to the filtration system if plumbing size is greater than 2" diameter or if flow rates are greater than 120 gpm. The bypass loop should be after the filter and always before a chemical dispenser.

If the Nature² vessel will be installed below the water level of the pool, use valves to isolate the vessel and prevent the pool from draining during installation and cartridge changes.

All PVC fittings must be attached to the Nature² base using standard PVC cement. The vessel should be set on a firm base.

1. Install a tee in the return line to allow water to divert to the Nature² vessel. Then connect the tee to the vessel inlet.
2. Install a control valve in the return line after the first tee and before the second tee.
3. Fully open any valves (including the control valve) that were closed to isolate the vessel.
4. Start the pump allowing water to pass through the newly plumbed system. The control valve in the return line between the two (2) tees will control the flow through the vessel.
5. With the control valve open, read the pressure on the filter gauge.
6. Adjust the control valve until the filter gauge increases by 1.5 psi.

Note: For flows in excess of 120 gpm with the Nature² vessel in bypass, do not exceed 1.5 psi increase in filter backpressure. Once 1.5 psi is reached, flow is correct through the vessel.
7. Check the vessel for leaks. Fix or replace leaking fittings.

*The Nature² vessel can be reduced to accommodate 1.5" plumbing by using reducing bushings. These bushings will have no effect on the operation of the Nature² vessel.

Operation and Maintenance

Refer to the Nature² Cartridge Owner's Manual for cartridge start-up procedures.

Filtration and Circulation

Follow the manufacturer's directions for keeping the circulating pump in good working order and operate it at least six (6) hours a day. Consult your Nature² dealer for optimum run times.

Check the pool filter periodically and clean as recommended by the manufacturer.

Replacing the Nature² Cartridge

Use the month indicator ring on the top of the unit to identify the date on which the cartridge should be replaced. A Nature² cartridge lasts six (6) months. To replace the cartridge:

1. Shut off your pool's pump and filter.
2. Close any valves between the filter and pool to prevent draining the pool.
3. Unscrew the locking ring counterclockwise and remove. Lift cap straight off. You may need to gently rock back and forth to remove.
4. Remove the old cartridge.
5. Insert the new cartridge.
6. Place cap so it rests flat on the housing base. Screw locking ring clockwise until snug: Do not overtighten. Make sure o-ring is secure in the groove on the underside of the cap and not on the vessel.
7. Rotate the month indicator ring on the cap top so that the current month is visible in the installation window.
8. Open any valves that were closed to isolate the Nature² vessel.
9. Restart your pool's pump. Check for leaks and fix any leaking fittings.
10. Follow the start up procedures included with your Nature² replacement cartridge.

Installing The Month Indicator Ring

1. Insert the ring (with small o-ring in place) into the hole in the center of the cap.
2. Apply pressure with the palm of the hand until the ring slips down into place.
3. Adjust the month indicator ring to the appropriate month.

Troubleshooting

Use the guide below to correct common pool issues. For further assistance, consult your Nature² dealer or call us at 1-800-822-7933.

Problem	What to look for:	Treatment
The vessel leaks	1. O-ring missing or improperly seated	Make sure o-ring is secure in the groove on the underside of the cap and not on the vessel.
	2. Faulty plumbing	Repair source of leak in plumbing.
No flow to vessel	Dirty filter (one indication: pressure is 8-10 psi higher than normal)	Clean or backwash filter so operating pressure is always within 7 psi of a new filter.

Nature²® Professional G Vessel Limited Warranty

The limited warranties contained within this document are the only warranties given with your Nature² Professional G Vessel and supercede any prior warranties. **All other warranties, expressed or implied, including the implied warranty of merchantability or the implied warranty of fitness for a particular purpose are hereby disclaimed.** Our sole obligation under this warranty, and the purchaser's sole remedy, is limited to repair or replacement of the Nature² Professional G Vessel, or one of its parts. The Nature² warranty applies to the original owner only.

THE LIMITED WARRANTIES OF THE NATURE² PROFESSIONAL G VESSEL ARE:

The Nature² Professional G Vessel you have purchased is warranted to be free of defects and materials and workmanship for a period of five years from the date of purchase. Your warranty registration card must be completed and mailed to Nature² to establish your installation date.

EXCLUSIONS FROM WARRANTY

Nature² Professional G Vessel is designed for use on in-ground pools up to 45,000 gallons, dependent on replacement cartridge size. If the unit is used in any other application, the warranty is void, and the purchaser and/or pool owner releases the manufacturer from any and all claims related to the use of the Nature².

This warranty does not cover problems arising in whole or in part from purchaser's negligence, misuse or abuse, improper maintenance or storage, accident, improper installation, improper application, failure to follow all appropriate safety precautions, Acts of God, abnormal weather conditions, damage from plants or animals, and improper use of chemicals.

This warranty specifically excludes all incidental or consequential damages, except where state law requires them to be paid. This warranty gives you specific rights. You may have other rights that vary from state to state.

TO SUBMIT A CLAIM

Report claims to Zodiac Pool Systems, Inc. by calling 1-800-822-7933. Only the original purchaser may submit a claim under this limited warranty. All claims must be accompanied by an original purchase receipt.

ZODIAC POOL SYSTEMS, INC.
2620 Commerce Way
Vista, CA 92081
Tel: 800-822-7933
Fax: 877-327-1403
www.zodiacpoolsystems.com